

1550nm Internal Modulation Optical Transmitter

With AGC/MGC



Operator's Manual

MODEL: ST1550I Series

I. Main Technical Characteristics

The transmitting modules of this machine adopt the imported DFB laser named SEI and so on.

The internal RF driving amplifier and controlling circuit of this machine can ensure the best C/N. The perfect and stable circuit of optic power output and controlling circuit of thermoelectric refrigeration device of laser module assure the user the best quality and stable working for a long time.

The internal micro-processor software has many functions such as laser monitoring, number display, trouble alarm and on-line management. Once the working parameter of the laser is out of the fixed range, there will be a red light glistening to alarm.

The RS-232 standard connector makes it is possible to manage on line and monitor in another place.

The machine adopts 19"standard shelf and it can work with the voltage from 110V to 254V.

II. Display Board Operation Guide :

Press the button "Status" in the board, the working parameter of this machine can be seen in turn as follows,

1.Model : ST1550I-02,04,06,08,10,12

2.Output Power: display the output power of this machine (mW) .

3.Laser Temp: the laser works between 20°C and 30°C.If the

temperature is out of this range, the red light will glister to warn.

4. Bias Current: The bias current of the laser is the main working parameter of the laser. Only when the parameter is above 30mA, RF driving circuit can begin to work. The red light will shine to warn when the RF driving level comes out of the fixed value.

5. REFRG Current : showing the working current of heating or cooling which can make sure the standard temperature is 25°C.

6. + 5V test (Reads) : showing internal actual Voltage of $\pm 5V$.

7. - 5V test (Reads) : showing internal actual -5V.

8. +24V test (Reads) : showing internal actual voltage of +24V.

III. Operating Guide :

- 1 Please examine this machine, shelf and the power to see if the power supply is good.
- 2 This machine adopts the switch power with high quality and high stability which makes it is suitable to work in voltage from 110V to 254 V.
- 3 Please make sure the connector is clean before installation. Please clean the fiber connector with pure alcohol before connecting the fiber.
- 4 After connecting the power, please turn on the power in the back of the board. The screen will show the basic information of this machine. After several seconds, the laser power will turn on automatically. If the

machine is all right, the condition guide light (Laser) will turn from red to green. And the screen will show you the working condition of this machine at present.

- 5 Press the button "STATUS", then you can see the parameters of this machine in turn.
- 6 If all the above working condition is all right, then examine whether the RF input level can satisfy the request in the test report. If it is all right, please connect the RF input to the transmitter.

IV. Notice

1. Before installation or operation of unit, please carefully go through this manual.
2. ST1550I Series Transmitters should be serviced only by qualified personnel.
3. Before proceeding with installation and/or operation of transmitter, please assure that transmitter is well earthed.
4. ST1550I Series transmitters are Class III laser products. Use of controls, adjustments, and procedures other than those specified herein may result in hazardous laser radiation exposure.

V. Diagram

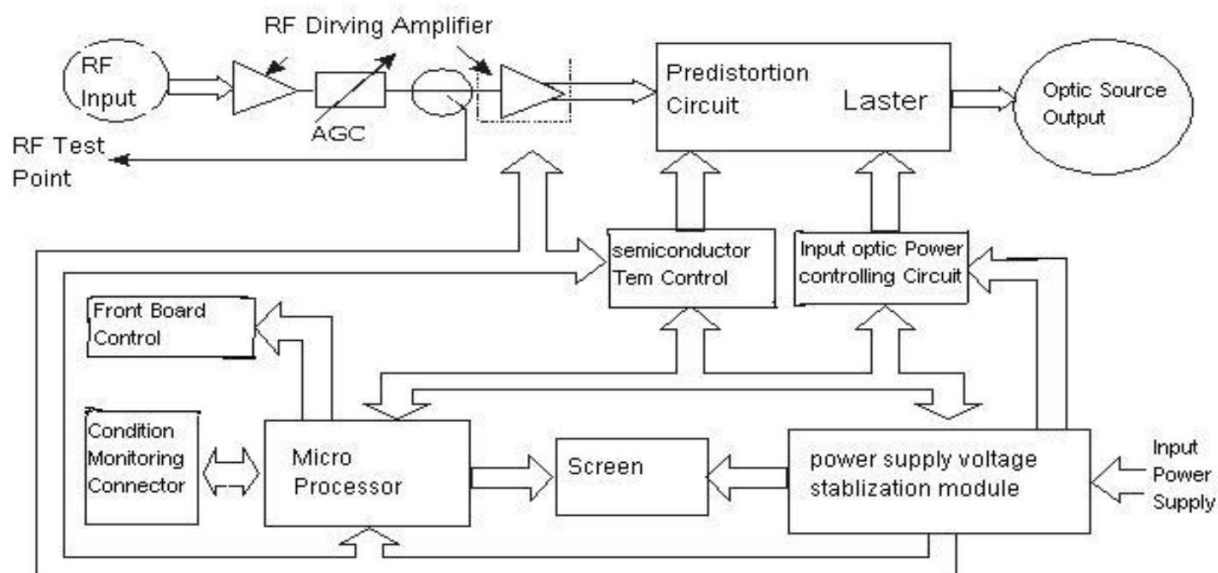

VI. Main Technical Parameters

Model (ST1550I)	-04	-06	-10	-12
Optic Power (mW)	4	6	10	12
Optic Power (dBm)	6.0	8.0	10.0	10.8
Optic Wavelength (nm)	1550±20			
Fiber Connector	FC/APC、SC/APC、SC/UPC (Selected by the Customer)			
Working Bandwidth (MHz)	47~862			
Channels	59			
CNR (dB)	≥51			
CTB (dB)	≥65			
CSO (dB)	≥-60			
RF Input Level (dBμV)	Not with pre-distortion		78±5	
	With pre-distortion		83±5	
Band Unflatness	≤0.75			
Power Loss (W)	≤30			

Power Voltage (V)	220V(110~254) OR -48VDC
Working Tem (°C)	-20~85
Size (mm)	483×370×44

VII. Warranty Term

ST1550I Series optical transmitters are covered by ONE YEAR LIMITED WARRANTY, which starts from the initial date of your purchase. We provide its customer whole-life technical supports. If warranty is expired, repair service only charges parts (if required). In the event that a unit must be returned for service, before returning the unit, please be advised that:

1. Warranty mark pasted on the housing of unit must be in good conditions.
2. A clear and readable material describes model number, serial number and troubles should be offered.
3. Please pack the unit in its original container. If the original container is no longer available, please pack the unit in at least 3 inches of shock absorbing material.
4. Returned unit(s) must be prepaid and insured. COD and freight collect can not be acceptable.

NOTE: we do not assume responsibility for damage caused by improper packing of returned unit(s).

The following situation is not covered by warranty:

1. The unit fails to perform because of operators' faults.
2. Warranty mark is modified, damaged and/or removed.
3. Damage caused by Force Majeure.
4. The unit has been unauthorized alteration and/or repaired.
5. Other troubles caused by operators' faults.

Conversion of Optical Power

mW	1	2	3	4	5	6	7	8	9	10	11	12	13	14	15	16
dBm	0.0	3.0	4.8	6.0	7.0	7.8	8.5	9.0	9.5	10.0	10.4	10.8	11.1	11.5	11.8	12.0
mW	17	18	19	20	21	22	25	32	40	50	63	80	100	125	160	200
dBm	12.3	12.5	12.8	13.0	13.2	13.4	14	15	16	17	18	19	20	21	22	23